

# STANDS

Reference Guide

# STANDS

---

## AD-SB

For **T245-A**, **T210-A** and **T470-A** soldering handpiece.



## AP-SB

For **AP130-A** solder feed iron.



## PA-SB

For **PA120-A** micro hot tweezers.



## HT-SB

For **HT420-A** hot tweezers.



## DS-SB

For **DS360-A** micro desoldering iron.



## DR-SB

For **DR560-A** desoldering iron.



---

All these stands can be connected to the following JBC stations: **DI**, **DD**, **DM** and **RM**.

## CL9885 TIP CLEANING STAND

The most complete cleaning accessory, allowing you to choose between 3 different cleaning methods: metallic wool, metal brush and sponge. Use the integrated wiper to remove excess solder from the tip, you can tap the tip on the wiper profile or you can wipe any possible particle stuck to the tip using the slots. Due to its weight and antislip bumpers, it is totally self contained, portable and ideal 1 for handed use, there is no need to hold with a hand while you are cleaning the tip



### OPTIONAL

CL6205 Inox wool

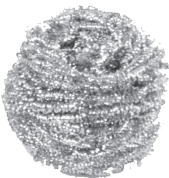

CL6220 Brushes

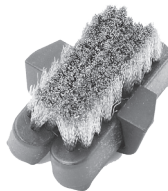

TT-A Tip Tinner



# STANDS

---

## CABLE COLLECTOR ASSEMBLY

---

Assembly for **AD, AP, PA, HT** stands.

---



Assembly for **DR** and **DS** stands.

---



## CHANGING THE HADPIECE CARTRIDGE

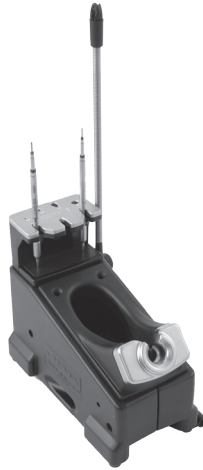

With the JBC system, the cartridge can be changed quickly, without turning off the station, so you have multiple soldering irons in one.

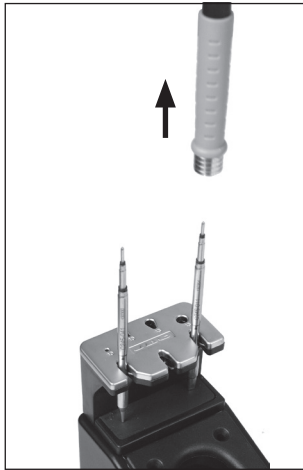

**1** - Insert the cartridge connected to the handpiece in a slot and pull up slightly to release it.

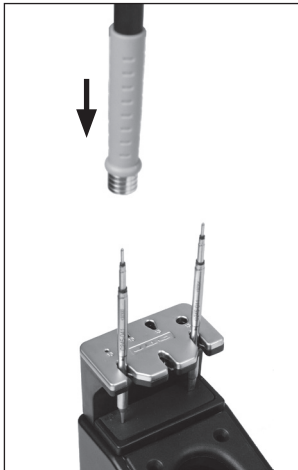

**2** - Insert the cartridge to be used into the handpiece, push slightly and remove it from the slot.

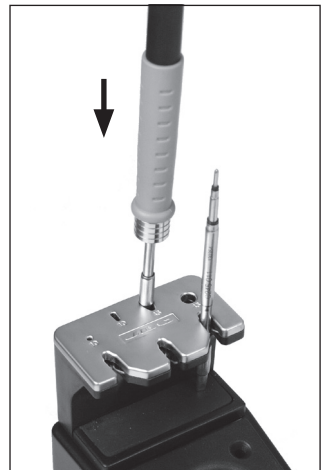

**3** - Press the cartridge into the suitable hole depending on the tip's shape.

### Important.

It is essential to insert the cartridge till the end for a good connection. Use the mark  as reference.

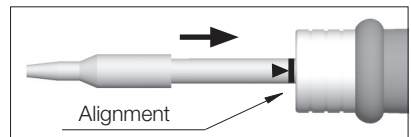

# STANDS

---

## CABLE STAND AND SUCTION TUBE EXTENSIONS

---

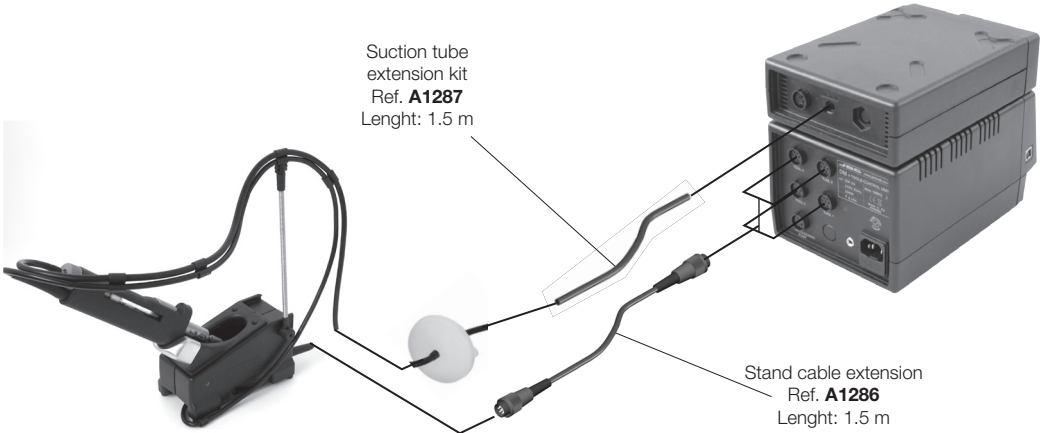





This product should not be  
thrown in the garbage.

---

**JBC**

---

#### WARRANTY

The JBC 2 years warranty, guarantees this equipment against all manufacturing defects, covering the replacement of defective parts and all necessary labour.

Warranty does not cover product wear due to use or mis-use.

In order for the warranty to be valid, equipment must be returned, postage paid, to the dealer where it was purchased enclosing this, fully filled in, sheet.

---

SERIAL N°

---

STAMP OF DEALER

---

DATE OF PURCHASE

---

---

**MORE INFORMATION**  
**[www.jbctools.com](http://www.jbctools.com)**

0003790-0911